



water ...the lifeblood of the land

PITLESS ADAPTER FOR SUBMERSIBLE PUMPS

In the past, a well pit was used to provide a frost-free connection between the distribution line and the drop pipe of a submersible pump in a small diameter well (shown in Figure 1). Agri-Water **does not recommend** this construction as it has several disadvantages including:

- being a potential danger to children
- frequently causes well pollution by housing rodents
- it is not convenient for well and pump servicing

In addition, frost may cause well pit casings to heave resulting in a fracture of the discharge pipe where it passes through the well pit casing. By using a pitless adapter, (Figure 2) these problems are avoided.

The pitless adapter is more economical, sanitary, safer and sightlier than a well pit. Its below ground placement provides a frost-free connection and a sanitary method of connecting the discharge pipe to the drop pipe as shown in Figure 2.

The unit is designed with a quick-disconnect mechanism that allows easy access to the well for servicing and for shock chlorination (see Water Facts "Shock Chlorination for Iron Bacteria Control"). It also provides a quick and easy method for removing the submersible pump from the well.

Pitless adapters are sold commercially and may be installed by well drillers, plumbers or farmers.

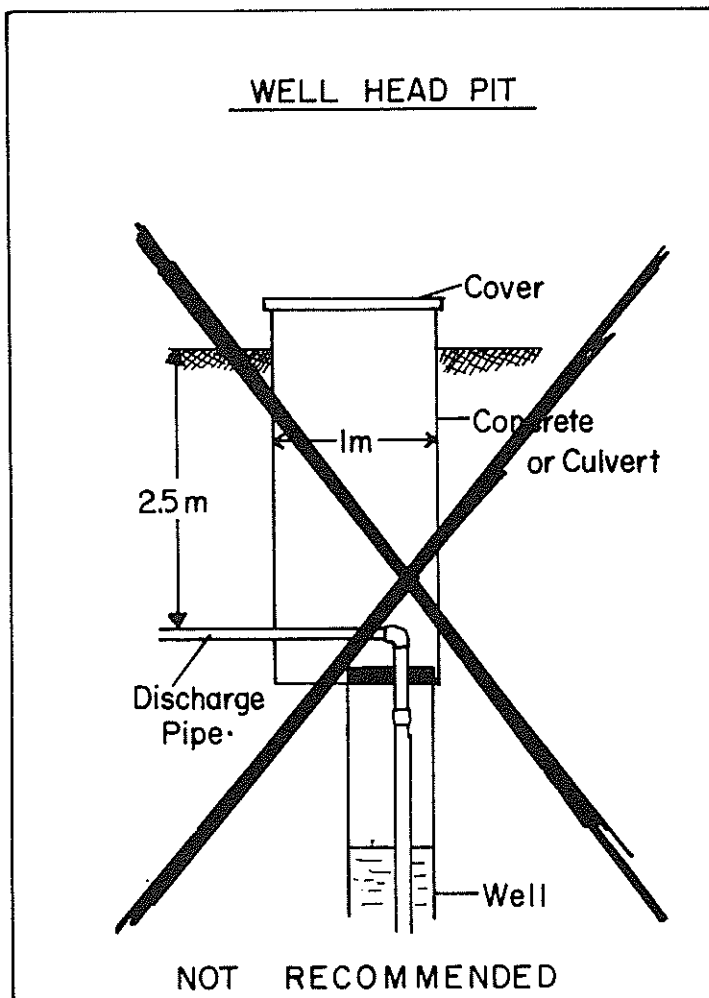

Figure 1

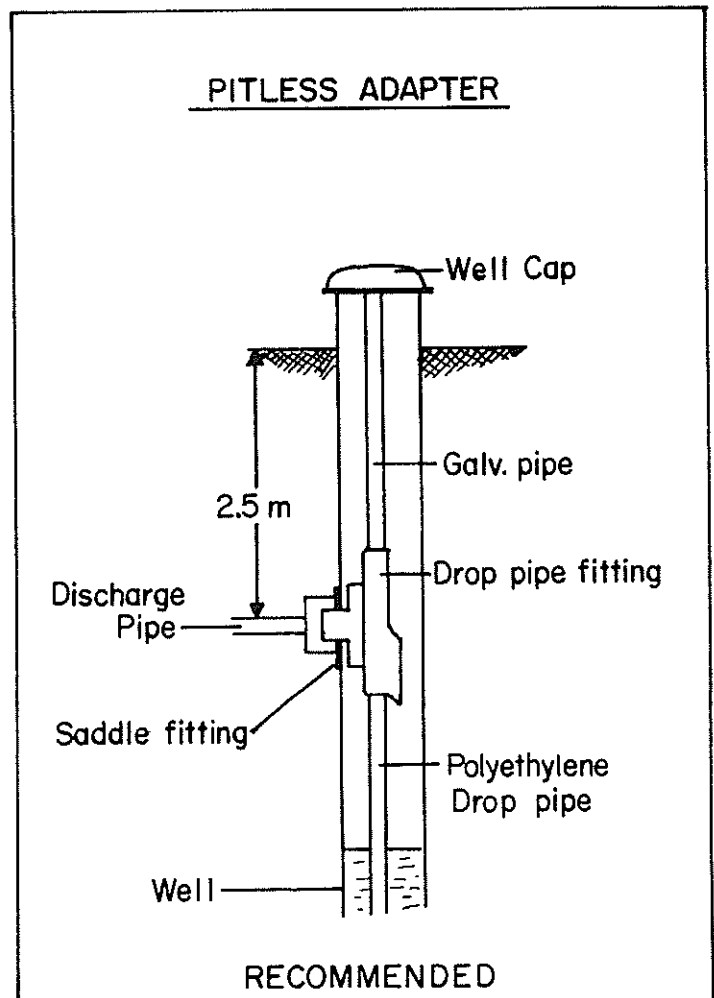
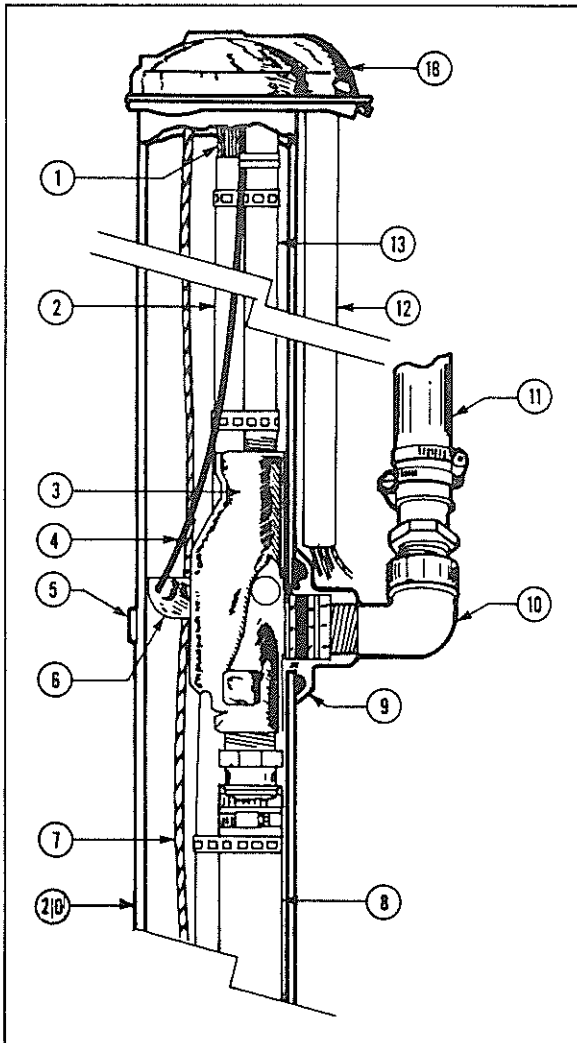

Figure 2

Pitless Adapter Construction

Although various types of pitless adapters are available, the spring loaded types are most commonly used. Figure 3 shows the detailed construction and connection of this type. The following list of components is applicable to Figures 3-8, inclusive:

1. Electrical cables
2. 20mm or 25 mm (3/4 in or 1 in) polyethylene pipe (used to protect cables)
3. Drop pipe fitting
4. Release cable
5. "U" clamp
6. Spring loaded actuator
7. Safety rope
8. Drop pipe
9. Saddle fitting
10. 90° street elbow
11. Discharge pipe
12. Conduit (metal or PVC)
13. 25mm (1 in) galvanized pipe
14. "O" ring
15. Rope hook
16. Bowline knot
17. Tee handle
18. Well cap
19. Drop pipe fitting neck
20. Well casing



Installation Procedure

1. Excavate around the well casing to a depth of no less than 2.5 m (8 ft).

WARNING: To prevent caving, all excavations must be shored or excavated at 45° to the bottom metre (3 ft.) in all soil types. This is in accordance with The Manitoba Workplace Safety and Health Act. Contact Manitoba Environment, Workplace Safety and Health for a permit and further information.

2. Tighten the drop pipe fitting to a 25mm (1 in) galvanized pipe (Figure 4) and hold it along the outside of the well casing so the top of the galvanized pipe is 25mm (1 in) above the casing. The drop pipe fitting must be a minimum of 2.5 m (8 ft) below the ground surface. If necessary extend the release cable (Item 4, Figure 4).

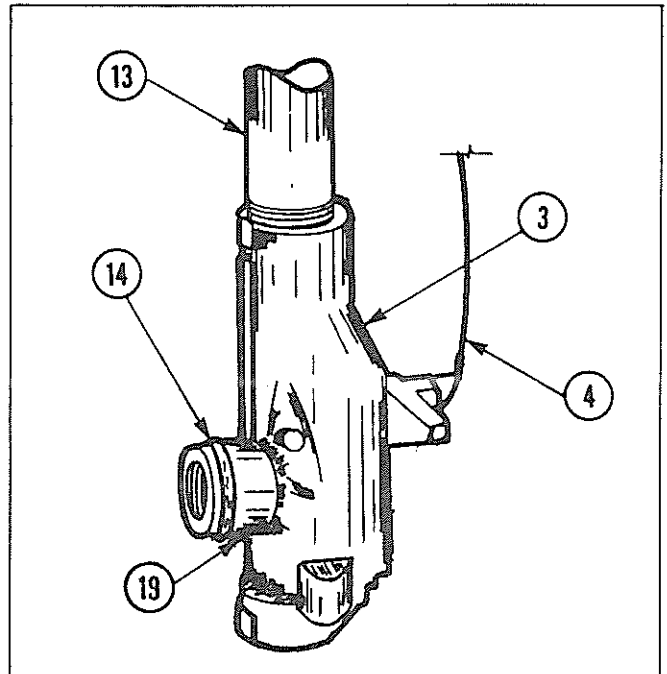
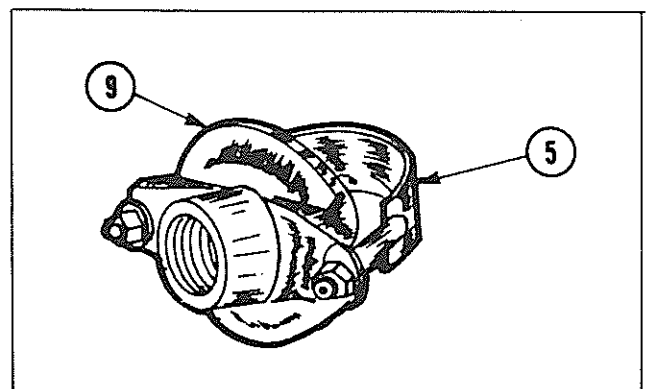

Figure 4

3. Mark the location of the drop pipe fitting neck on the well casing, drill the pilot hole, and cut the casing with a 60mm (2 3/8 in) diameter hole saw. The hole should be at a right angle to the discharge pipe and a minimum of 2.5m (8 ft) below the ground surface.



4. Using a half round file remove the steel burrs to smooth both the interior and exterior of the hole in the casing.
5. Position the saddle fitting and "U" clamp (Figure 5) on the outside of the casing over the drilled hole. Tighten the "U" clamp evenly until the outer edge of the saddle fitting snugs the casing.
6. Tighten a 90° street elbow onto the saddle fitting until the fitting is pointing 20° upward in the direction of the discharge pipe. Connect the discharge pipe as shown in Figure 6.

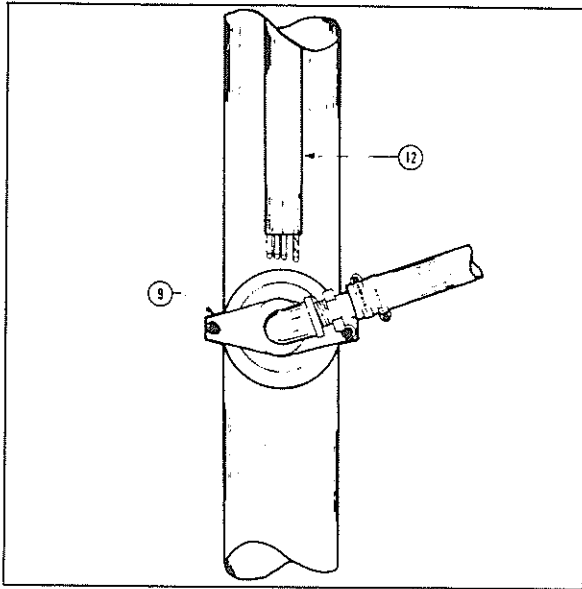

Figure 6

7. Permanently notch the top of the casing in line with the drilled hole in the casing as completed in Step 3.
8. After the discharge pipe is connected, pack sand around the casing until the discharge pipe connection is covered to a depth of 150mm (6 in). Carefully complete backfilling.
9. Construct a Tee handle using two 25mm x 150mm (1 in x 6 in) galvanized nipples and a 25mm (1 in) galvanized tee (Figure 7). Hand tighten the Tee handle onto the 25mm (1 in) galvanized pipe that connects to the drop pipe fitting.

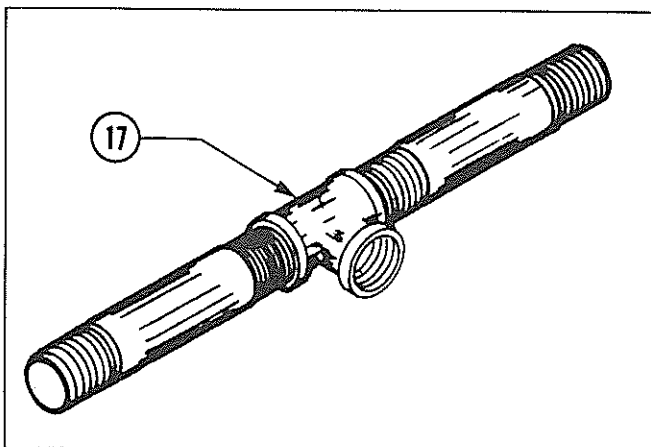

Figure 7

10. Connect the drop pipe, electrical cable and safety rope to the submersible pump. Tie the safety rope using a bowline knot (Figure 8). Lubricate the "O" ring on the drop pipe fitting neck (Figure 4) with clean petroleum jelly (vaseline). Lower all of the above into the casing. The Tee handle and notch in the top of the casing are used to line up the drop pipe fitting neck (Figure 4) with the saddle fitting. The Tee handle will also prevent the pump from falling into the well. When the Tee handle comes within 50mm (2 in) from the top of the casing, the drop pipe fitting will align with the saddle fitting. The spring loaded actuator in the drop pipe fitting will then snap the neck into the saddle fitting, sealing the connection and locking the two together.
11. The nylon safety rope, minimum size 8mm (5/16 in), may be attached by fabricating a hook from a piece of 3mm x 25mm x 350mm (1/8 in x 1 in x 14 in) flat iron (Item 15, Figure 8).

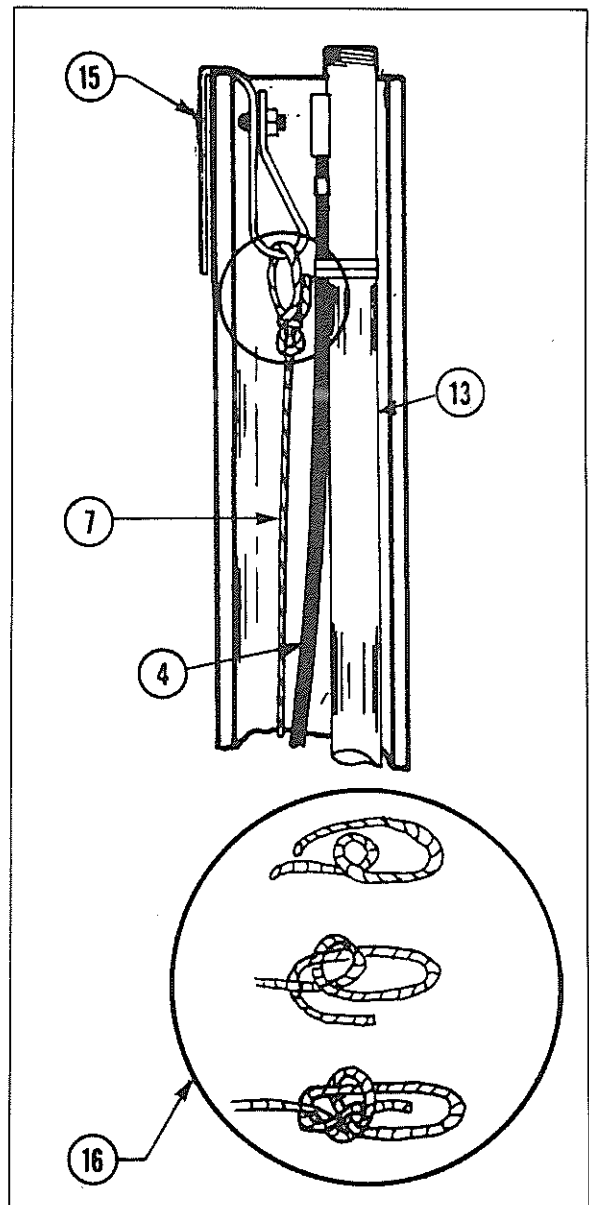

Figure 8

12. Tape the release cable to the 25mm (1 in) galvanized pipe (Figure 8).
13. Remove the Tee handle and store for future use.
14. Install the well cap.

Removal Procedure

1. Remove the well cap.
2. Thread the Tee handle onto the length of 25mm (1 in) galvanized pipe.
3. Release the drop pipe fitting by pulling on the release cable. (Be prepared for the full weight of system).
4. Pull the complete assembly from the well.